

NB. De aanduiding op de thermostaat kan verschillen met de aanduiding op dit schema (Lees L en N worden L1 en L2). Het betreft potentiaalvrije thermostaten, aansluiting op de regelaar (N en L) is dan ook willekeurig.

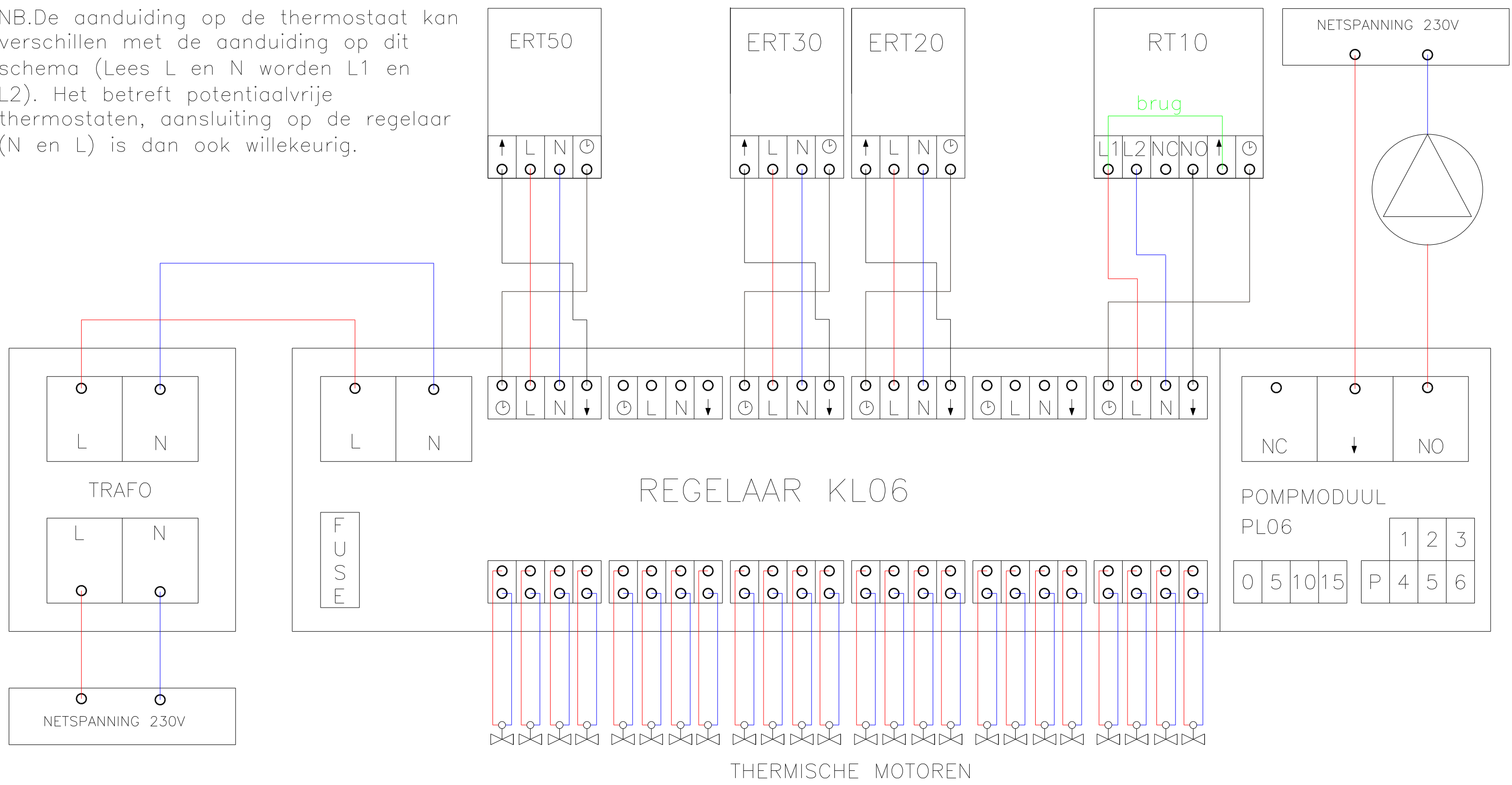

NETSPANNING 230V

ERT50

ERT30

ERT20

RT10

brug

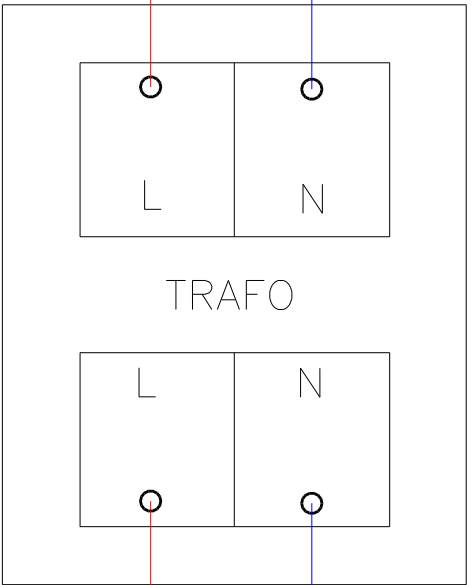

NETSPANNING 230V

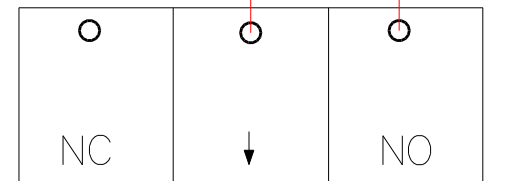
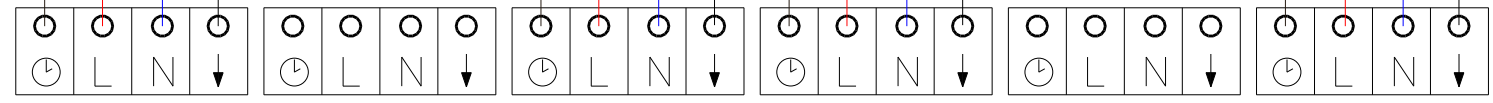
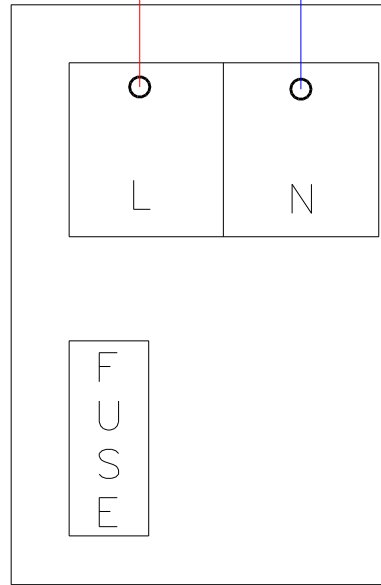

				1	2	3	
0	5	10	15	P	4	5	6

